

PAPER • OPEN ACCESS

Retrieving Surface Soil Moisture from Optical Satellite Imagery over Medan and Surrounding

To cite this article: Togi Tampubolon *et al* 2020 *J. Phys.: Conf. Ser.* **1485** 012008

View the [article online](#) for updates and enhancements.

You may also like

- [Study on Remote Sensing Retrieval of Soil Moisture in Arid Desert Area Based on FTVDI](#)
Zhao Lu, Daqing Wang, Zhibin Ding et al.
- [DENSITY-MAGNETIC FIELD CORRELATION IN MAGNETOHYDRODYNAMIC TURBULENCE DRIVEN BY DIFFERENT DRIVING SCHEMES WITH DIFFERENT CORRELATION TIMES](#)
Heesun Yoon, Jungyeon Cho and Jongsoo Kim
- [The Spread Of Dry Area Based On TVDI Index \(Temperature Vegetation Dryness Index\)](#)
A Aisyah, E Kusratmoko and A Wibowo



The Electrochemical Society
Advancing solid state & electrochemical science & technology

243rd ECS Meeting with SOFC-XVIII

Boston, MA • May 28 – June 2, 2023

**Abstract Submission Extended
Deadline: December 16**

[Learn more and submit!](#)

Retrieving Surface Soil Moisture from Optical Satellite Imagery over Medan and Surrounding

¹Togi Tampubolon, ¹Rita Juliani, ¹Juniar Hutahean, ²Jeddah Yanti

¹Department of Physics, State University of Medan, Indonesia, Jln. William Iskandar, Ps. V, Medan, 20221, Sumatera Utara, Indonesia

²Center for Space and Remote Sensing Research, National Central University, Republic of China

Corresponding author: topartam@gmail.com

Abstract. The Earth's environmental surface have change in local, regional and also global scale in any environmental parameter. Medan, one of big city or region in Indonesia, has fluctuated tropical climate in hydrological cycle. Soil moisture is a key variable in the hydrologic processes that play an important role in determining the availability of water as a fundamental element in human life. Soil moisture is an important parameter for many processes' hydrology, biology and biogeochemistry. The aim of this study to integrated soil moisture over land area in Medan and surrounding. One of the existing methods to obtain information about soil moisture is Temperature-dryness Vegetation Index (TVDI). TVDI a drought index that is determined based on the empirical parameters of the relationship between surface temperature (TS) and vegetation index (NDVI). The index is associated with soil moisture and obtained only by the input of satellite remote sensing information. Dataset use Landsat 5 TM during 2005 to 1989, Landsat 7 ETM image for 2011, and Landsat 8 OLI for 2014 - 2016. Vegetation index value calculation using InfraRed band (4 to Landsat 5 TM and Landsat 7 ETM or 5 for Landsat 8 OLI) and Band Shortwave InfraRed (5 for Landsat 5 TM and Landsat 7 ETM or 6 for Landsat 8 OLI). The result will be classified from low to high value TVDI. TVDI maximum value each period of the years showed value above > 0.5 that means from moderate to high moisture. From the linear function of TVDI shows the decreasing soil moistures during those time period that assumes assumed the source of soil moisture decreasing conditions due to the surface runoff that resulting in a change in vegetation area and surface temperatures. Reduction of a soil's capacity to accept, retain, release and transmit water reduces biomass productivity, whether of crops, pasture species, shrubs or trees.

Keywords: Soil Moisture, NDVI, TS, Landsat, Medan

1. Introduction

Terrestrial ecosystems stability reaches out the regulating energy exchange, hydrological cycle, and climate change through photosynthesis, surface albedo, and roughness. This sequence is recognized as a natural linkage between the pedosphere, atmosphere, and hydrosphere of the Earth's systems. As a key variable for monitoring hydrological cycle, soil moisture is an important parameter to all pieces off [1]. It also plays a fundamental element in water existence for the well-being and health of human populations. Soil moisture might be determined soil formation based on the empirical relationship



parameters between land surface temperature (T_s) and vegetation index (NDVI). Temperature-dryness Vegetation Index (TVDI) is the most widely employed method to execute soil moisture [2].

Nowadays, The Earth's environmental surface have change in local, regional and also global scale [3]. All negative effects of any comprehensively occurring changes, the potential for degraded land and the level of drought severity. Therefore, this research aims to prevent droughts by analyzing the changes in humidity and finding the relationship between land surface temperature and vegetation index. To accomplish the research purpose, we need an effective way to solve those problems. TVDI index is associated with the effect of soil moisture and obtained by the input of satellite remote sensing information [4].

Tropical country is almost entirely a tropical climate that is a zone of climate characterized by humid weather. Indonesia is one of the tropical countries in Southeast Asia, while Medan and the surrounding areas are one of the big cities in Indonesia [5]. Medan has a tropical climate with the minimum temperatures of 23.99°C in 2013 and the maximum temperature of 32.11°C according to Polonia station. Tropical country also relates with natural disasters when Indonesia over the years is rising, for instance an earthquake which were 72 cases in 2009, 122 cases in 2010, 120 cases in 2011 and becomes 92 cases in 2012. The earthquake causes the land to change. Land changes in terms of geography [6].

Remote sensing is a sophisticated technology to monitor a wide range of problems existing on Earth surface comprehensively, such as forest fires, land conversion, soil moisture and increasing of the Earth's surface temperature [7]. The remote sensing method using Landsat's image satellite having metadata and image satellite to estimating ecological studies and an understanding of surface components. Landsat Program is a series of Earth-observing satellite missions jointly managed by NASA and the U.S. Geological Survey. This technology is extremely useful for understanding the spatiotemporal land cover change in relation to the basic physical properties in terms of the surface temperature data [8].

Soil moisture relates with the presence of vegetation in a particular area and land surface temperature anomaly. It has been used by the researches from multidiscipline to understand about characteristic of vegetation trough several vegetation indexes. The evolution of satellite technology indicates dramatically the interesting of land and sea observations including the studies about soil moisture. We are using multi-temporal Landsat TM/ ETM + /OLI satellite data since 1989 to 2014. Previous study focusses on the key components of terrestrial ecosystems such as vegetation role in regulating energy exchange, the carbon cycle, and climate change through photosynthesis, surface albedo, and roughness and is recognized as a natural linkage between the pedosphere, atmosphere, and hydrosphere of the Earth's systems. It has increasingly become a hot topic in the response of vegetation to land surface temperature whether it has attracted considerable to soil moisture [9], [10], [11].

2. Area of Interest

Total Area is covered $203,417\text{ km}^2$ with 2 main locations. It becomes Medan City and Its coastal. Medan area can be seen in Figure1, the research areas are located as follows:

1. Start from coordinate 443625.00 E , 444255.00 N to 510435.00 E , 444255.00 N stretches from East to West.
2. Start from coordinate 443625.00 E , 386865.00 N to 443625.00 E , 444255.00 N stretches from North to South.
3. Start from coordinate 443625.00 E , 386865.00 N to 510435.00 E , 386865.00 N stretches from East to West.
4. Start from coordinate 510435.00 E , 444255.00 N to 510435.00 E , 386865.00 N stretches from North to South.



Figure 1. Study Area

3. Materials

The research material used in the form of spatial data and attribute data as follows Satellite imagery Landsat 5 TM, Landsat 7 ETM+ and Landsat 8 OLI provided by <http://glovis.usgs.gov/> [12]. This Landsat image has specific requirement such as path 057 and row 129, land area covered less than 10% cloud cover. Landsat consists of 8 band at least where each band represent wavelength coverage and functions. The characteristics of Landsat can be seen on Table 1.

Table 1. The Characteristics of Landsat 7 ETM+ spectral band Imaginary Satellite

Band	Wave length (μm)	Spectral	Functions
1	0,43 – 0,45	Blue	Used for mapping at the coastal area
2	0,52 – 0,60	Green	Used for observation the top of vegetation reflection in green canal to know the condition of vegetation
3	0,63 – 0,69	Red	Used for differentiating kinds of vegetation. The absorption by chlorophyll will make the differentiating between open land and vegetation land be easier.
4	0.76 – 0.90	Closed Infrared	Used for delineation water and land. It is sensitive to vegetation biomass.
5	1.55 – 1.75	Middle I infrared	Used for differentiating kinds of vegetation, Water containing in the plants, and land humidity condition. It also used for differentiating between snow and clouds.
6	10.40 – 12.50	Thermal Infrared	Used for differentiating rocks formation and mapping hydrothermal mapping.
7	2.08 – 2.35	Middle II infrared	Used for vegetation classification, land humidity differentiating, vegetation disruption analysis, land, rocks, and water differentiating.
8	0.52 0.90	Visible Ray and Closed Infrared	Used for observation the object at the earth surface with higher spatial resolution

4. Methods

The procedure will be beginning from describe the image pre-processing. There is a map informing the land cover, land use, and topography condition over Indonesia area in several scales ranged from 1:100000 to 1:25000.

4.1. Geometric Correction

In Geometric correction, the correction was applied on each pixel of image that already exist coordinates, therefore it was the necessity of GCP (Ground Control Point). GCP is a couples point to the initial image (not corrected) and reference (maps, image correction) to correct the systemic distortions in the initial image. The process to perform the geometry correction includes apply ENVI 4.7 software and then run the data which used to open appears on the display layer, then open the Landsat image file to be corrected by generating a second display.

4.2. Radiometric Correction

Radiometric correction has various methods to perform radiometric correction on the satellite image. It used the method of Top of Atmosphere (ToA) correction was a correction to the image for omitting radiometric distortion caused by the position of the sun. The position of the sun to the earth was changed depends on the acquisition time and the location of the object. To A correction has been done by changing the value of the digital number to reflectance values. To A Reflectance correction has been done by converting the DN value to the reflectance values [7]

Calculation correction of To A reflectance with ENVI 4.7 make tools *band math* with formula of conversion equation for correction of To A reflectance

$$\rho = M \cdot Q_{cal} + A \quad (1)$$

Calculation correction of To A reflectance with ENVI 4.7 make tools *band math* with formula of conversion equation for sun elevation

$$\rho = \frac{\rho_r}{c(\theta)} = \frac{\rho_r}{s(\theta)} \quad (2)$$

where:

ρ = TOA reflectance

θ = angle of elevation (sun elevation), 58.12601448

θ_{sz} = solar zenith angle, $\theta_{sz} = 90^\circ - \theta$

4.3. TVDI Calculation

TVDI calculations performed using the equation below obtained for dry and wet regions from the calculation of NDVI and temperature estimation in Landsat TM, ETM+, and OLI for some observation points in the Microsoft Excel [13]. After the equation obtained later TVDI value can be calculated using function Band Math in software ENVI [14]. Finally, the result used to output the file if you want to save result be file or memory to work Temporarily or not stored.

$$TVDI = \frac{T - T_{min}}{T_{max} - T_{min}} \quad (3)$$

Where:

T_{min} = The minimum surface temperature on the wet side of the triangle define

T = Surface temperatures observed at a pixel

NDVI = Vegetation index values observed

$a; b$ = Parameter that defines the dry side ($T_{max} = a + b \cdot NDVI$)

T_{max} = The maximum surface temperatures observed for each value of NDVI

Flow chart could be seen in Figure 2. as follows

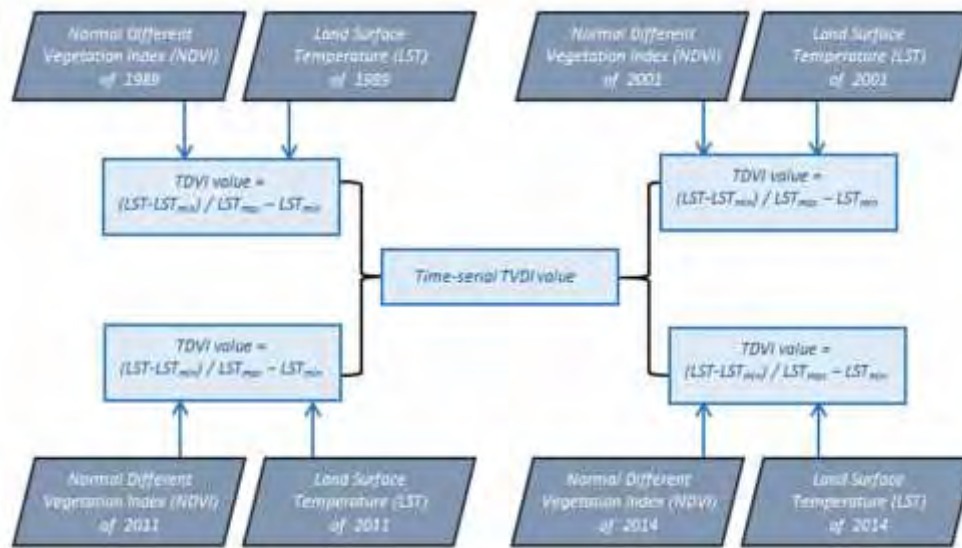







Figure2. TVDI Value in Coastal Area of Medan

The result will be classified with criteria of TVDI. Criteria of TVDI could be seen in Table 2(Pravalie, 2014).

Table 2. Criteria of TVDI

Classification	Color	Interval
Very Low		< 0
Low		0.0000001 - 0.25
Moderate		0.2500001 - 0.5
High		0.5000001 - 0.65
Very High		>0.65

5. Result and Discussion

TVDI value obtained by making equation by using LST (Land Surface temperature) NDVI formula (Normal Different Vegetation Index) by utilizing the band on Landsat imagery. For 2005 and 1989 using the Landsat 5 TM, in 2011 using Landsat 7 ETM image, and for 2014 using Landsat 8 OLI. Vegetation index value calculation using InfraRed band (4 to Landsat 5 TM and Landsat 7 ETM or 5 for Landsat 8 OLI) and Band Shortwave InfraRed (5 for Landsat 5 TM and Landsat 7 ETM or 6 for Landsat 8 OLI). The results of change detection value could be seen Figure 3.

Results from the classification TVDI in 1989, 2005, 2011 and 2014 for the NDVI index value with a range of value ranges from -1 to 0 indicated that an area was a region with very low moisture, 0 to be identified with low moisture 0.25, 0.25 up to 0.5 identified as moderate moisture, 0.5 to 0.65 are identified to be high moisture, and index values above 0.65 are identified to be very high. TVDI calculations obtained from the change in value of soil moisture can be seen in Table 3.

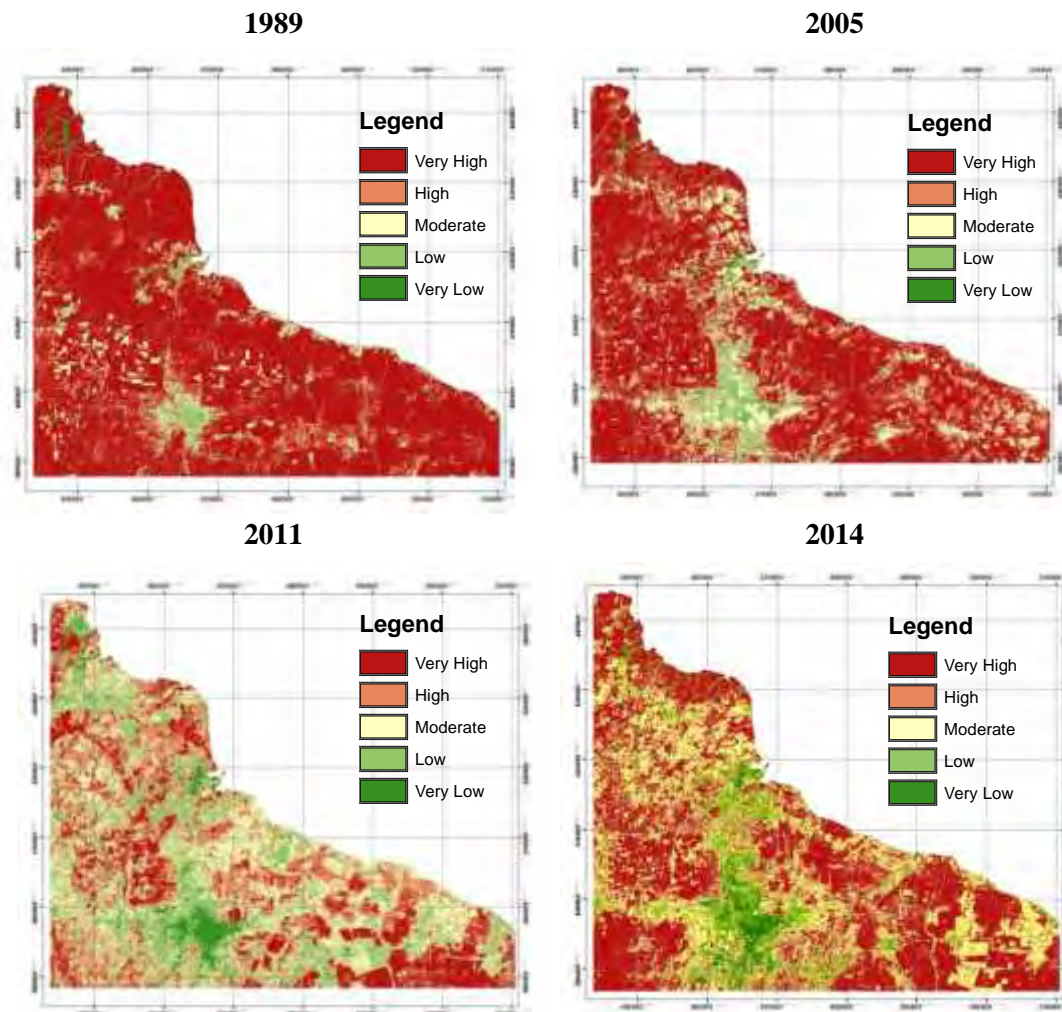

Figure 3. Coastal on Medan area on TVDI from Landsat

Table 3. TVDI Value 1989, 2005, 2011 and 2014 to the city of Medan and coastal areas

Years		TVDI Value	Area (ha)	Percentage (%)
1989	TVDIAverage	0.514	13524.93	6.887
	TVDI max	0.857	155256.93	79.067
	TVDI min	0.171	1108.62	0.564
2005	TVDIAverage	0.51	15237.35	11.697
	TVDI max	0.806	139816.18	72.251
	TVDI min	0.201	2278.5	0.977
2011	TVDIAverage	0.508	26397.36	14.042
	TVDI max	0.844	118977.84	63.293
	TVDI min	0.168	1177.74	0.626
2014	TVDIAverage	0.471	36921.42	18.151
	TVDI max	0.785	98781.12	48.561
	TVDI min	0.157	4000.14	1.966

Moisture values could be seen in Table 4.8, in 1989 Landsat image value range 0.171 to 0.857 with an average value TVDI is 0.514, for 2005 the range of values 0.201 to 0.51 with an average value TVDI is 0.806, for the year 2011 range of values 0.168 to 0.844 with an average value TVDI was 0.508, for 2014 the range of 0.157 to 0.785 with an average value TVDI was 0.471. With the range of values TVDI can be said that the variation moisture in the area of research and for the 4-year study

period the average value TVDI decline could be seen in Figure 4, which means the transition of an area or field of moisture into non moisture. With regard TVDI maximum value each period of the year showed the number above >0.5 . From the results TVDI average value for each year can be made charts the changes, which shows a graph that has not been linear so it is necessary to obtain a linear function equation graph changes stating TVDI, it has been an increase in the value of TVDI. Graph of TVDI average could be seen in Figure 4.

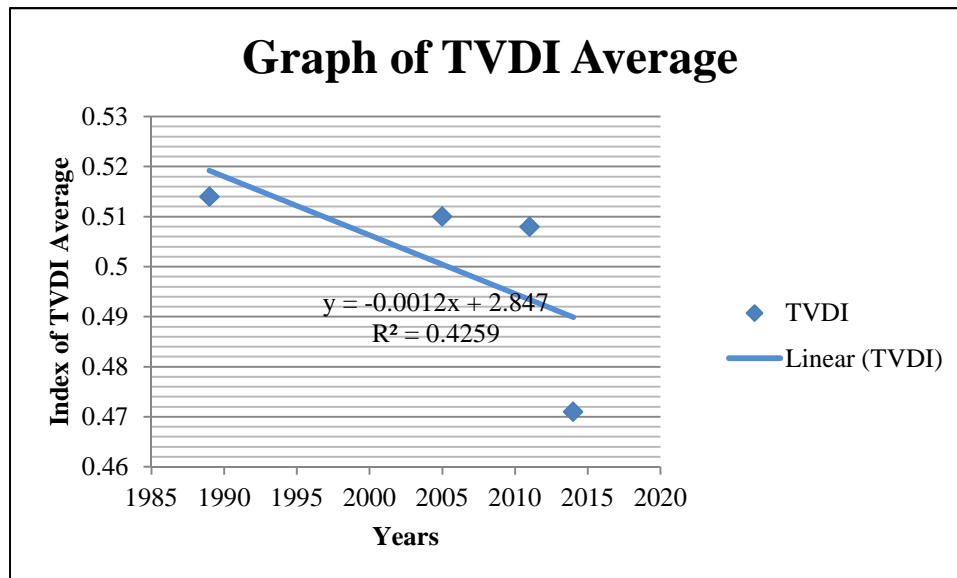

Figure 4. Graph of TVDI Average for 1989 - 2014

Soil moisture represented a key variable in the coupling of the land and atmosphere, since it controlled the partitioning of available energy between sensible and latent heat flux at the surface. Consequently, soil moisture variability driven by the atmosphere may feed back onto the near-surface climate—in particular, temperature. In this research, the land use change from vegetated area, with high or low cover, to the non-vegetated area has been assumed as the source of soil moisture decreasing conditions due to the surface runoff that resulting in a change in surface temperatures. Theory corresponding with the of soil moisture. In some papers, it also reported that the decrease of soil moisture may cause a major flux of CO₂ from terrestrial ecosystems caused by microbial decomposition of soil organic matter, that seen as a feedback to climate change. Although climate-carbon models suggest that warming will accelerate the release of CO₂ from soils, the magnitude of this feedback was uncertain, mostly due to uncertainty in the temperature sensitivity of soil organic matter decomposition [11].

Soil moisture is the quantitative water content in terms of volume (volumetric) or mass (gravimetric) among soil probes [3]. Reduction of a soil's capacity to accept, retain, release and transmit water reduces biomass productivity, whether of crops, pasture species, shrubs or trees [10]. After a few seasons, it may cause by productivity declines and that part of this decline associated with the degradation of soil physical conditions. It was less commonly recognized that this soil damage and the loss of organic matter resulted in increasing surface runoff and reduced soil moisture status. Surface runoff was a condition where the soil became unreceptive, less porous and that much of the rainfall was ineffective in supporting plant growth and regular stream flow [10].

6. Conclusion

The Conclusion in this research is the identification result of satellite analysis shows that land humidity parameter from year 1989, 2005, 2011 to 2014 shows that there is the reduction as width 0.043357 Ha that causes environmental change. Based on the conclusion obtained through this research, the author realized that the similar research activities should be carried out regularly with some additional methods and parameters for the purpose of monitoring and rehabilitation. Several

additional parameters such as soil type, temperature, humidity, pH, and legal parameters as Region and City Design Plan (Rencana Desain Tata Ruang Daerah dan Kota) to conduct more comprehensive study of a future land management. As for activities related to agriculture, there should be monitoring and restrictions that forest area as the primary source of land clearing activities still has its ecological functions. The results can be predicted by the model equations, so it needs further reduction of relating parties. The prediction results occur if there is no follow-up in terms of physical, etc. The results of this study can be contributed as physical science, especially geophysics, supporting of government policy to environmental changes, and as a tool for monitoring environmental changes to predict future results.

References

- [1] Bergh, A., R. Benjamin, R. & K.L. Lintner. (2012). Impact of Soil Moisture–Atmosphere Interactions on Surface Temperature Distribution. *Journal of Climate*, 27, pp.7976–7993. doi: <http://dx.doi.org/10.1175/JCLI-D-13-00591.1>.
- [2] Chen, et al. (2015). Temperature Vegetation Dryness Index Estimation of Soil Moisture under Different Tree Species. *Sustainability*, 7, pp. 11401-11417.
- [3] Jin, M. S., Mullens, T. (2014). A Study of the Relations between Soil Moisture, Soil Temperatures and Surface Temperatures Using ARM Observations and Offline CLM4 Simulations. *Journal of Climate*, 2, pp.279-295.
- [4] Sandholt, I., K. Rasmussen, J. Andersen. (2002). A simple interpretation of the surface temperature/vegetation index space for assessment of surface moisture status. *Remote Sensing of Environment*, 79, pp.213– 224.
- [5] Dimiyati M., K. Mizuno, S. Kobayashi, T. Kitamura. (1996). An analysis of land use/ cover change using the combination of MSS Landsat and land use map-a case study in Yogyakarta, Indonesia. *International Journal of Remote Sensing*, 17. pp.931–944. <http://dx.doi.org/10.1080/01431169608949056>
- [6] *Climatology Meteorology and Geophysics*, (2019). Medan Statistic Information. <https://www.bmkg.go.id/cuaca/prakiraan-cuaca.bmkg?Kota=Medan&AreaID=501580&Prov=35>
- [7] USGS, (2019). What is Remote Sensing and What is it used for?. <https://www.usgs.gov/faqs/what-remote-sensing-and-what-it-used>
- [8] Price, J.C. (1980) The potential of remotely sensed thermal infrared data to infer surface soil-moisture and evaporation. *Water Resour. Res.* 16, pp.787–795.
- [9] Meng, L., Y. Shen. (2014) On the Relationship of Soil Moisture and Extreme Temperatures in East China. *Earth Interact.*, 18, pp.1–20.
- [10] Shaxson, F., R. Barber. (2003). Optimizing soil moisture for plant production: The significance of soil porosity. *Food and Agriculture Organization of The United Nations Soils Bulletin* 79. ISSN 0253-2050.
- [11] Suseela, V., T. Richard, Conant, D. Matthew, Wallenstein, S. Jeffrey, Dukes. (2012). Effects of soil moisture on the temperature sensitivity of heterotrophic respiration vary seasonally in an old-field climate change experiment. *Global Change Biology*, 18(1), pp.336–348.
- [12] Witter, J. (2004). Deriving a TVDI from Landsat 5 Imagery for The Oak Opening Region of Northwest Ohio. Spring 2004 Digital Image Analysis Final Project.
- [13] Parwati & Suwarsono, (2008). Model Indeks TVDI (Temperature Vegetation Dryness Index) untuk Mendeteksi Kekeringan Lahan Berdasarkan Data MODIS-Terra. *Jurnal Penginderaan Jauh*, 5, pp. 35-44.
- [14] Zhao, W., A. Li. (2013). A Downscaling Method for Improving the Spatial Resolution of AMSR-E Derived Soil Moisture Product Based on MSG-SEVIRI Data. *Remote Sens*, 5, pp.6790-6811.